



PRODUCT INFORMATION PACKAGE

Think aluminium windows, think Aluminco!

Contact Us

1300 095 180

www.alumincowindows.com.au

A little about us...



“ Our new Aluminco windows are great quality and look fantastic. They have transformed our home. The Aluminco team were professional, worked to schedule, and had great attention to detail. They were also lovely to deal with. ”

-Leah S



With over 30 years' experience in commercial windows, Aluminco Windows and Doors are the authority in aluminium windows and doors. We supply and install any custom sized aluminium windows and doors to suit any project requirements.

Beginning with your FREE Measure and Quote, our engineers will discuss with you the aesthetic you want to achieve, the function and size of each window, as well as guide you with any structural and engineering requirements

We are always available to support you throughout the entire process, and provide solutions. And you can rest assured knowing that our products and services are certified per Australian Standards, are Australian made, and come with a 10-Year Workmanship Warranty.

At Aluminco we pride ourselves on supplying the highest quality products, the best possible service, and providing you with our wealth of knowledge and experience, our attention to detail, and our impeccable craftsmanship.



“ So happy that I chose Aluminco Windows. The staff were prompt, very helpful and lovely to deal with. Love my windows - thanks Aluminco Windows! ”

-Maria B



“ The windows are great... I can already feel the difference in heating and cooling the house and I just love driving in and seeing them... such a difference. I would 100% recommend the business... professional and friendly all the way ”

-Joanne N



WHY CHOOSE ALUMINIUM?



Here's why we think you should choose aluminium...

Durable

Aluminium is strong, durable, and does not warp, rot, or bend. It's rigid and light, and can withstand harsh weather conditions, lasting far longer than timber alternatives. The strength of aluminium frames can also allow for larger window sizes that timber or PVC windows can't tolerate

Cost Effective

As a material, aluminium frames are far cheaper than wood and steel, and far easier to manufacture. Their durability ensures longevity, so you won't need to worry about any additional costs for replacements

Low-Maintenance

Aluminium windows are incredibly low-maintenance, needing nothing more than a quick wipe with a cloth whenever you see fit to make them look as good as new! Powder coating will eliminate the need to ever paint your windows, unlike other materials such as timber, which is also prone to warping, rotting and eventually needing replacing

Energy Efficient

Now more than ever, people are choosing more environmentally friendly solutions and products for their homes. As we head toward a 'greener' future, aluminium is leading the way as the ideal framing system for windows and doors. Not only is aluminium 100% recyclable, but aluminium windows and doors can help increase your homes energy efficiency, by controlling heat retention and loss. Therefore, you'll be lowering your emissions and reducing your carbon footprint, while saving money by reducing your energy bills.

Aesthetic

Aluminium has long been the window and door frame choice for architects, builders, designers, and other industry professionals. The light, slick, architectural/commercial look of the frame adds an incredible modern and elegant aesthetic to any space. Plus, there is a range of powder coating colours for you to choose from!



OUR PRODUCTS



Awning Windows

Awning Windows are a perfect option for ventilating your home! They are hinged from the top allowing them to swing outward opening from the bottom. Their slanted opening provides your home with an extra level of security, making it very difficult for an intruder to enter, as well as preventing any unexpected rain from coming in and wetting your interiors. Our commercial frames give Awning Windows the highest level of performance against strong winds, and air and moisture protection.

Perfect for: Providing ventilation on those wet hot summer days!

Popular use: Bedrooms, bathrooms

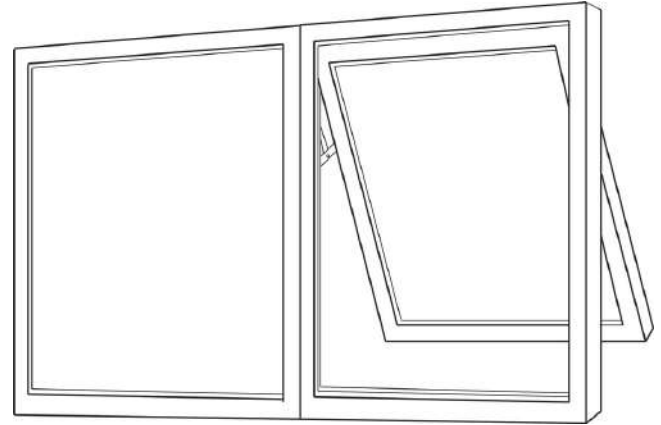

Sliding Windows

Sliding Windows are a popular choice of windows, and are very practical for when there is limited space around the window. The openable panel slides neatly along a fixed panel, making it a compact window choice that doesn't protrude into open areas or walkways. They have a simple design and are extremely easy to operate, offer all-out airflow, and are a classic in Australian homes.

Perfect for: Leaving partly open for ventilation without the risk of heavy winds slamming them shut

Popular use: Bathrooms, laundry

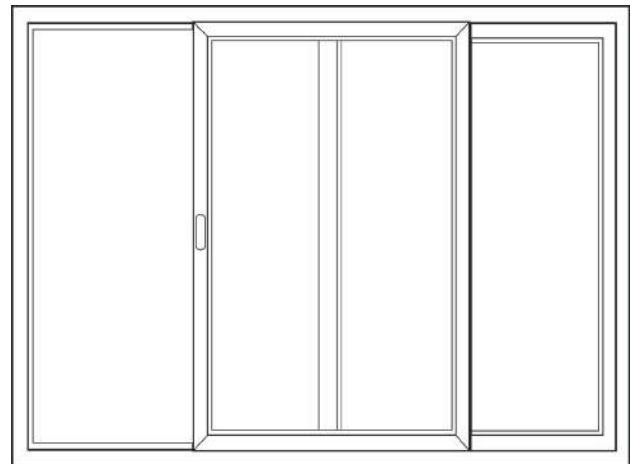

Fixed Windows

Fixed Windows are the perfect feature windows to maximise natural light and give your home an open and spacious feel! And you can go as big or as small as you'd like - the strength of our commercial frames allows for window sizes that other materials can't tolerate. There's nothing we love more than huge fixed windows that we can crane lift to your home!

Perfect for: Maximising natural light

Popular use: Living rooms, family rooms, dining areas, alfresco areas, swimming pool areas



OUR PRODUCTS



Servery or Bi-Fold Windows

Servery or Bi-Folds are a very popular and versatile window with a wide opening which maximizes airflow. They are a great way to open the inside of your home to the outside. Servery Windows can be fully opened to not only increase your views by up to 90%, but also to deliver an expansive and spacious feeling to your home. They are space saving, elegant, easy to open and close, and come in many configurations – including your choice of opening inward or outward.

Perfect for: Opening your home when entertaining family and friends for summer BBQ's

Popular use: Kitchens and alfresco areas

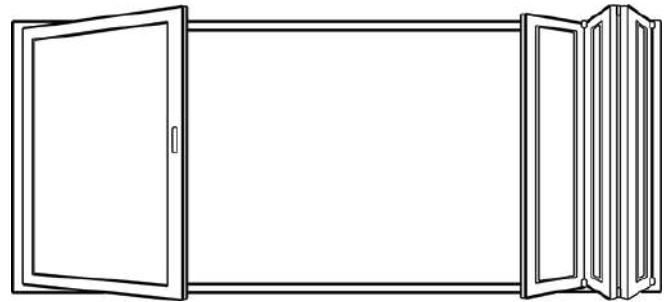

Sliding Doors

Sliding Doors are practical and cost-effective, making them one of the most popular options for linking the inside of your home with the outside. Just like their window counterparts, Sliding Doors have an openable panel that slides neatly and away from view along a fixed panel, making them a compact choice that don't protrude into open areas or walkways. They have a simple design and are extremely easy to operate, offer all-out airflow, and are a classic in Australian homes.

Perfect for: Leaving partly open for ventilation without the risk of heavy winds slamming them shut.

Popular use: Balconies, alfresco areas

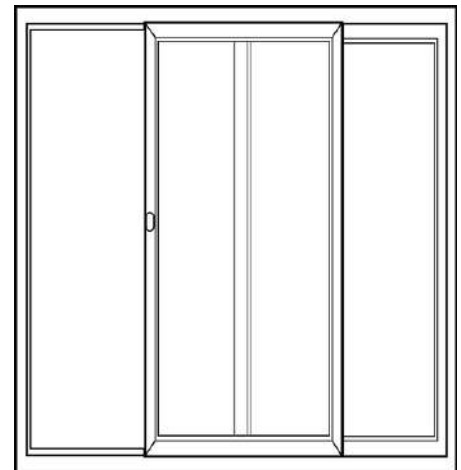

Stacker Doors

Stacker Doors are a great option for wider than usual openings. They are very easy to operate, and function similar to their cousins, the Sliding Door, except Stacker Doors have two openable panels that slide neatly and away from view onto a fixed panel, giving you a much larger unobstructed opening. This large opening is a great way to maximise natural light, and control airflow by simply opening the doors to their entirety, or only to half way.

Perfect for: Wider than usual door openings that maximise natural light

Popular use: Balconies, alfresco areas

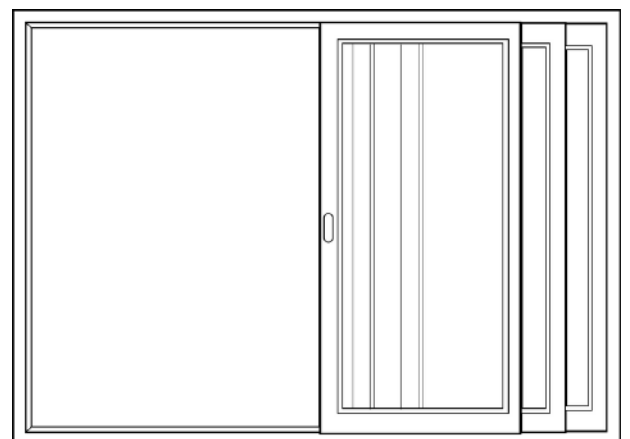

OUR PRODUCTS



Bi-Fold Doors

Bi-Fold Doors are our absolute favourites! By far the most popular door for creating a large, open plan, spacious home with unobstructed views. The ultimate in modern, architectural living! Bi-Fold Doors are space saving, elegant, easy to open and close, and come in many configurations – including your choice of opening inward or outward. You could even include a hinged door in your Bi-Fold to conveniently enter or exit without having to open the Bi-Fold. There is no better way to seamlessly connect the inside of your home to the outside!

Perfect for: Opening your entire floor plan when entertaining family and friends for summer BBQ's

Popular use: Living rooms, family rooms, dining areas, alfresco areas, swimming pool areas

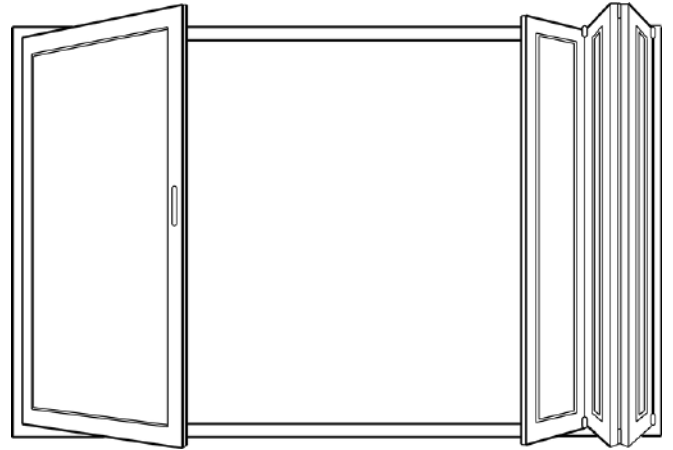

Our Windows and Doors...

- ✓ Close and seal tightly to prevent heat and cold transference (increasing their energy efficiency, and reducing your energy bills)
- ✓ Can be fitted with double glass for improved thermal performance and noise reduction
- ✓ Are strong, durable, and can withstand harsh weather conditions
- ✓ Will give your home a slick, modern, architectural look
- ✓ Come with a 10-Year Workmanship Warranty, 3 Month Warranty on Hardware, and 1 Year Warranty on Glass Against Defects

“ Aluminco replaced a bespoke sliding door and window combination at my home. The order process through to installation was seamless and the end result amazing. The quality of the door and window is exceptional. I would recommend Aluminco for your home or business ”

-Peter D



WINDOW SYSTEMS & FRAMES



Residential Systems

Residential Window Systems are the most popular choices for homes, particularly for Window Replacements.

*They are available in two Series: **Comet** - a more budget friendly option, and **Apollo** - a thicker and stronger frame*

Comet Series

The Comet **Sliding Window** is functional and economical. It has one fixed pane and one sliding pane that slides along a track inside the window frame allowing for maximum ventilation. With minimal components, it is highly functional and low in maintenance

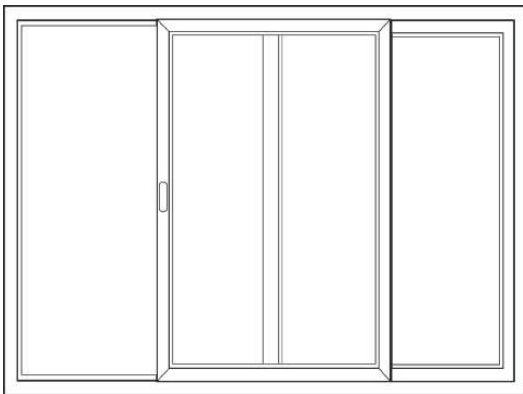

The Comet **Awning Window** is a cost effective window without structure compromise. We have developed a **53mm x 30mm** frame that meets Australian standards. It is a perfect window for entry level homes, unit developments and more.

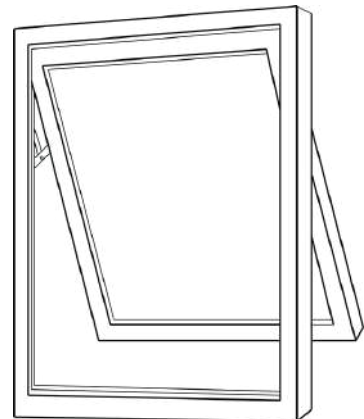

WINDOW SYSTEMS & FRAMES



Apollo Series (Semi-Commercial Lookalike)

The Apollo Awning window is our most popular window providing a balance between bold extravagance and practicality. With an impressive **90mm x 30mm** aspect, the Apollo brings just the right balance to your project. Strong enough for light commercial, can be used on low lying apartment projects where permissible.

Titan Series (Commercial Lookalike)

The Titan Awning window is a bold reflection of strength and luxury. With a stunning **90mm x 44mm** frame aspect, the Titan far exceeds wind load and water penetration tests making it ideal for your dream home. It's bold look is due to the extra large framework and will be a striking feature to your project.

WINDOW SYSTEMS & FRAMES



Commercial Systems

Commercial Frames have traditionally been the ideal choice for shopping centres, offices, show rooms, and commercial buildings, but they are also widely used in residential developments. Windows can be an important investment, so it's crucial to be sure you're purchasing a high quality, high performance product. And you really can't get a stronger, more durable frame than a Commercial one.

400 Series Single Glazed

101.6

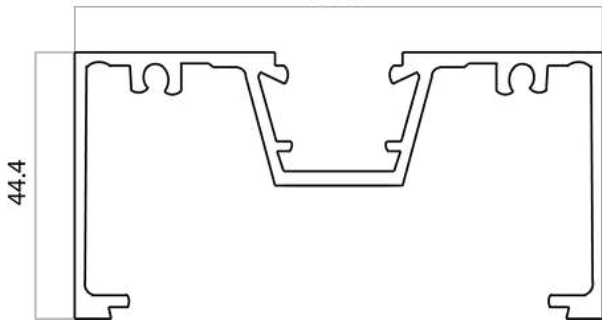

Accepts 4mm - 10,38mm Glass

400 Series Double Glazed

101.6

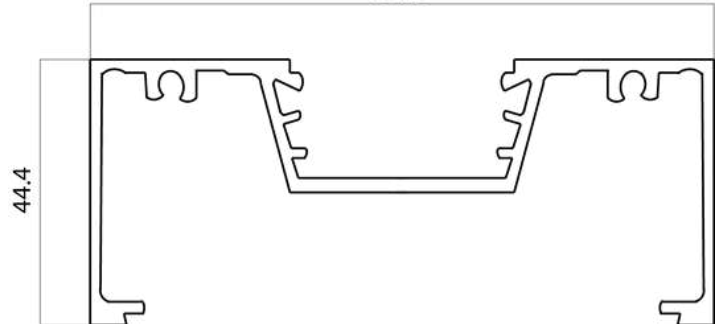

Accepts up to 24mm Glass



“ Very pleased with all the help, the service the quality and the price. It has opened up the area totally to create a whole new feel to the area ”

-Brad A

GLASS & GLAZING



For many years, the effect of glazing on energy performance, home comfort and safety had been greatly under-utilised in Australia.

Poorly designed windows and inefficient glass can make your home too hot or too cold, which increases reliance on artificial heating and air conditioning. Many Australian home owners are unaware of the high performance options available, but carefully chosen glass will help you maintain year round comfort and even reduce your power bills, as well as make your home safe and secure.

Although ensuring compliance with the Building Code of Australia is crucial, there are a few other factors to consider when choosing your glass type. For example - security, noise reduction, maximizing natural light, and lowering energy consumption are all important discussion points to make sure you're making the best possible choice for your home.

The choice in glazing options has grown dramatically in recent years, with some of the more commonly used glass types being:

Float Glass

Float Glass is the common glass that tends to break into large, jagged shards. It is used in some end products - often in double-glazed windows, for example. It is also the starting material that is turned into more advanced products through further processing such as laminating, toughening, coating, etc. Float glass process is renowned for flatness and optical clarity



GLASS & GLAZING



Toughened Glass

Toughened glass is treated to be far more resistant to breakage than simple float glass, and to break in a more predictable way, thus providing a major safety advantage in almost all of its applications. Counteracting stresses give toughened glass its increased mechanical resistance to breakage, and are also - if it does break - what cause it to produce regular, small, typically square fragments rather than long, dangerous shards that are far more likely to lead to injuries. Toughened glass also has an increased resistance to breakage as a result of stresses caused by different temperatures within a pane.

Toughened glass has extremely broad applications. Glass portions of building façades, glass sliding doors and partitions in houses and offices, and many other products typically use toughened glass.

Insulated Glass Units (Double Glazing)

Two or more panels of glass are bonded to a perimeter spacer, either a metal or thermoplastic spacer, (TPS). Either air or argon gas fills the space between the glass panes. Their primary benefit is insulation and solar control. Most types of glass can be incorporated into an insulating glass unit.

Laminated Glass

Laminated glass is made of two or more layers of glass with one or more "interlayers" of polymeric material bonded between the glass layers. Laminated glass offers many advantages. Safety and security are the best known of these - rather than shattering on impact, laminated glass is held together by the interlayer, reducing the safety hazard associated with shattered glass fragments, as well as - to some degree - the security risks associated with easy penetration. Laminated glass is used extensively in building and housing products and in the automotive and transport industries. Most building façades and most car windscreens, for example, are made with laminated glass, usually with other technologies also incorporated.

Low-E Glass (Low Emissive)

Low-E glass has a low rate of emission - that is it has a lower rate than clear float glass of allowing heat to pass through the glass. In other words, if there is a heat source inside your house (or outside), the glass bounces the heat from that object back away from the glass.



“ I had Aluminco install double glazed windows to the front of my house 2 years ago. The quality of the product, customer service and their professionalism, made it a no brainer to get them to do the back of the house. They will also make customised windows to meet your requirements, which was such a lovely surprise. Cannot recommend the team highly enough ”

-Sarah J



A quick note on

SUSTAINABILITY

Aluminium itself is 100% recyclable, but as a whole system aluminium windows and doors can help increase your homes energy efficiency, by controlling heat retention and heat loss. Therefore you'll be lowering your emissions and reducing your carbon footprint, while saving money and reducing your energy bills. At Aluminco we are passionate about being environmentally responsible, and strive to lead the way in environmentally sustainable practices. We do this by constantly reviewing and implementing changes to our processes and business model, including waste reduction and management, updating machinery and equipment, and reviewing our designs and materials.

“ The whole team were amazing to deal with, fast response to all communication through the whole process and the installation process was a breeze! ”

-Elli P



WINDOW REPLACEMENTS



Our expertise extends seamlessly into the realm of Window Replacements. From the initial FREE Measure and Quote, our adept engineers collaborate with you, delving into your aesthetic aspirations, sizing requirements, and any structural nuances. Aluminco is not just a manufacturer; we are your partners throughout the journey, ready to troubleshoot and provide ingenious solutions.

There are many reasons why windows may need to be replaced including rotting, warping, constant maintenance requirements, letting cold air in through gaps, and faulty mechanisms. But all those problems, and more, can be resolved with Aluminium windows

They are durable, energy efficient, cost effective, and low maintenance. Aluminium is rigid and light, can withstand harsh weather conditions, and is cheaper than wood or steel. Their powder coating eliminates any need to ever re-paint the windows. This essential ensure that you won't need to worry about any additional costs.

From a purely aesthetic perspective, they're the perfect way to give your home a "face-lift" which will not only improve its appearance, but will also potentially increase the value of your home.

Before



After



Ask us about our...

ALUMINIUM ENTRY DOORS *e*-door

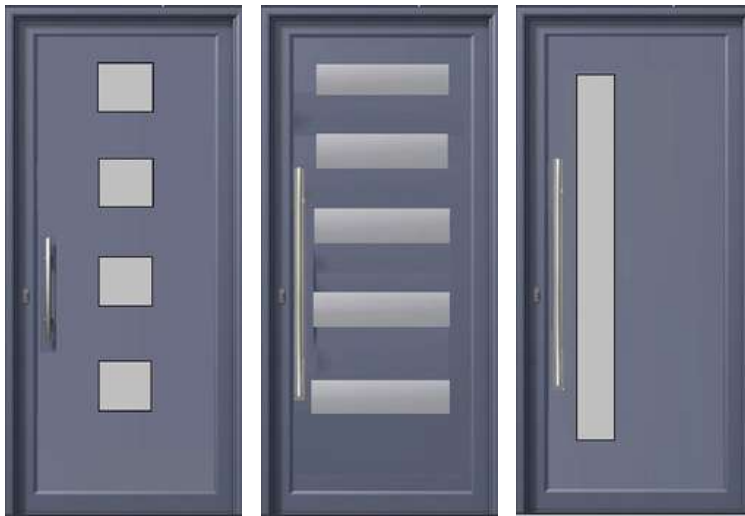

Features

- **Commercial Grade All Aluminium Entrance Door:** Combines durability, modern aesthetics, high security
- **Enhanced Durability:** Long-lasting performance and resistance to weathering
- **Customisable Design:** Colours and shapes
- **Ultimate in Security:** Robust design provides superior security
- **Incredible Aesthetic:** Modern, minimalist design that complements contemporary and traditional homes alike
- **No Maintenance Required:** Does not require regular painting or sealing



FREQUENTLY ASKED QUESTIONS



“The Aluminco team were like a breath of fresh air. They replied straight away, organised to come out and measure, and provided a quote days later. They did the job efficiently and the new window/door looks great. Highly recommended, and big shout out to the office who always answered my queries quickly and efficiently!”

-Rachael U

Can I put commercial frames in my home?

Absolutely! Customers who are either building a new home, or replacing their old windows, choose commercial frames for their durability and aesthetic. They are by far the superior choice of window systems, and add an incredibly modern, elegant and architectural look to any space.

What are your payment methods?

EFT is our most popular method of payment, and have Point of Sale facilities that accept all credit/debit cards. We have also partnered with **handypay** to offer financing options. For more information please contact our office on 1300 095 180.

What colours can I choose from?

There is a virtually endless selection of powder coating colours for you to choose from. At Aluminco, we use the Dulux Powder Coating chart.

Can I take measurements of my own windows and send them through to you?

You definitely can. Please contact us for instructions on how to do so, but please note that the measurements sent through are used for quoting purposes only. We will still need to conduct a site measure if you decide to go ahead with the project, so if there are any variances there may be a slight difference in price.

FREQUENTLY ASKED QUESTIONS



What does the process usually entail?

Once we receive your enquiry, we will call you to organise your Free Measure and Quote. We endeavour to provide you with a quote within 48 hours, which includes elevation drawings of your windows. If you decide to go ahead with your project, we will send an Invoice for our required 50% deposit. Once the manufacturing process has been completed, we will contact you to book in an installation date. Here we will issue an Invoice for the 40% Progress Payment. Depending on the size and type of project, installation time frames can vary from one day, to several weeks. Once the installation is complete, we conduct a final inspection (preferably with you present), we will remove all rubbish from site if you've selected us to, and forward through an invoice for the Final balance.



“ The team were fantastic from initial discussions through to measurement, quoting, removal and installation. Great communication throughout and the final product looks amazing. Can't go wrong with Aluminco - the windows and doors are top quality and reasonably priced and quick to manufacture and install. Would highly recommend them ”

-Dean L



ALUMINCO[®]

WINDOWS AND DOORS

Think aluminium windows, think Aluminco!

1300 095 180

contact@alumincowindows.com.au

www.alumincowindows.com.au

